

GLR2708

8-Channel 27MHz Gigalink™ Receiver with Open Collector Outputs

Features

- Wide supply connection – 10.0 to 28.0 Volts AC/DC
- Highly sensitive receiver input stage. When used with GLT27.... series transmitters and an ANT27L antenna, an operating range of 350 metres (980 ft) is possible.
- Eight open collector outputs. All outputs can be operated simultaneously.
- Crystal controlled for high stability and performance.
- Uses micro-controller technology that can be re-programmed to suit unique applications.
- Momentary, flip-flop and latching output modes is user selectable.



Applications

- automatic gates, security, timer controlled outputs and simple on/off functions etc.

Description

The GIGALINK™ is an advanced Remote Control technology available in the world today. GIGALINK™ is an invention that has revolutionised the entire Remote Control technology including Elsema's earlier version of FMT- ... and FMR- ... series. The GLR.... series state-of-the-art invention brings a new dimension in the world of Remote Control technology in domestic, commercial and industrial applications.

The innovative microcontroller technology replaces the traditional dip switch coding which eliminates any possible code grabbing. Special features such as over four billion code combinations, ability to program any number of transmitters to any of the receiver outputs, three user selectable modes, dual conversion superhet and operational over a wide voltage range all adds up to the most advanced and secure Remote Control available. The microcontroller built-in code programming system automatically selects the programming mode that provides flexibility in programming each receiver channel to different transmitter channels. In programming mode the receiver sends a random code to program the transmitter channel(s). Momentary joining the two CC pins on the receiver board sets all eight channels to a random code. To program the receiver to the transmitter channel(s) follow the steps outlined in the receiver instructions.

Code Programming

During single code programming, the 3-way dip switch selects the channel to be programmed. The table below shows the setting to select a different channel.

Dip Switch			Programmed Channel
1	2	3	
OFF	OFF	OFF	1
ON	OFF	OFF	2
OFF	ON	OFF	3
ON	ON	OFF	4
OFF	OFF	ON	5
ON	OFF	ON	6
OFF	ON	ON	7
ON	ON	ON	8

After selecting the correct channel, the receiver channel is ready to be single code programmed. Follow the steps outlined in the receivers instruction sheet titled single code programming to complete the code programming.

If all the receiver channels are to be programmed onto a multi channel transmitter, then follow the steps outlined in the receivers instruction sheet titled channelised code programming. This does not require the user to set the 2-way dip switch since all receiver channels will be programmed sequentially onto the transmitters channels.

The receiver power must be connected when single or channelised code programming.

When programming is completed and the GIGALINK cable is removed from the multi channel receiver-coding socket, the 4-way dip switch is used to select different output modes. This is described below.

Different Modes for each Output

Modes are user selectable from the 4-way dip switch, shown below.

(Dipswitch 4 is reserved for specific customer mode. Normally not used.)

DIP Switch Mode Settings	
The output relay will respond in the following manner when receiving the correct signal from a transmitter	
	"All Momentary": Relay on, only while correct signal is received
	"All Flip-Flop": Outputs alternate at every correct incoming signal
	"Momentary & Flip-Flop": Outputs 1-4 are momentary & 5-8 are flip-flop
	"Latching on": Outputs will be on until supply to receiver is momentarily interrupted
	"Momentary & Flip-Flop": Outputs 1-6 are momentary & 7-8 are flip-flop
	"Momentary & Flip-Flop": Outputs 1-2 are momentary & 3-8 are flip-flop
	"Momentary & Flip-Flop": Outputs 1-3 are momentary & 4-8 are flip-flop

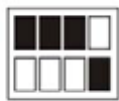

"Latching on": Output 1 is latching & 2-8 are momentary

*** Dipswitch 4 is reserved**

AC/DC Supply and Antenna

AC/DC power supply and antenna is connected to the 3-way terminal block. Do not connect the supply to the 2.5-mm coding socket since connection may damage the microcontroller.

Channels

The eight channels are solid state outputs using the ULN2803 Integrated Circuit. This IC is inserted to a socket that enables the user to easily change the output stage in case of a damaged output. The ULN2803 IC is available from Elsema. Output 1 being at the left and output eight to the right of the terminal block.

Dual Crystal Control

The GLR2708 is crystal controlled using dual conversion. Dual conversion is where the received frequency is mixed twice, using a crystal at both mixing stages. This results in less interference, enabling the receiver to operate in noisy industrial applications, improves operating performance, which allows the receiver to pass EMC and stringent radio regulations around the world.









Unique Code System

The microcontroller EEPROM allows large volume users to have a unique code. This enables Elsema to offer everyone "your own" radio control.

Case

The GLR2708 is supplied without a case, this allows the receiver to be integrated according to your needs.

Products in the Range

				
GLR2701 1-Channel	GLR2701240 1-Channel, 240V	GLR2702 2-Channel	GLR270312 GLR270324 3-Channel, 12 / 24V	GLR270412 GLR270424 4-Channel, 12 / 24V
				
GLR2708 8-Channel	GLR270812 GLR270824 8-Channel, 12 / 24V Relay Output	GLR27CS 1-Channel, Code Switch	GLR2701SS GLR2702SS 1,2 -Channel, Open Collector Output	

Technical Data

Supply Voltage	10.0 to 28 V AC/DC. Absolute maximum DC 40 Volts Can use Elsema 12-volt AC power pack (PP12) Supply lines should be less than 3 metres long to comply with radio frequency authorities
Current Consumption	11mA standby, 22mA if all outputs "On"
Receiver Type	Dual Conversion Superheterodyne
Receiving Freq	27.195MHz (Other freq available on 27.045, 27.145, & 27.455MHz. The 27.455 freq is not available for Australia)
Type of Crystal	10.245MHz, Fundamental, 20pf, 30ppm 16.495MHz, Fundamental, 20pf, 30ppm
Operating Temperature Range	-5 to 50°C

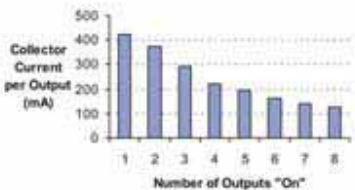
1 st IF Freq	10.7MHz																		
2 nd IF Freq	455kHz																		
Selectivity	-6dB at ±5kHz -20dB at ±6kHz																		
Type of Demodulation	Narrow-bandwidth Frequency Modulation (FM)																		
Sensitivity	1uV (for output to activate)																		
Image Rejection	At 26.285MHz better than -60dB																		
Occupied Bandwidth	±5kHz																		
Decoding System	Microcontroller (32-bit word 4.29 x 10 ⁹ codes)																		
Code Combinations	4,294,967,296																		
Outputs	<p>Eight Open Collectors (See chart for Collector Currents)</p>  <table border="1"> <caption>Collector Current per Output (mA) vs Number of Outputs "On"</caption> <thead> <tr> <th>Number of Outputs "On"</th> <th>Collector Current per Output (mA)</th> </tr> </thead> <tbody> <tr><td>1</td><td>420</td></tr> <tr><td>2</td><td>380</td></tr> <tr><td>3</td><td>300</td></tr> <tr><td>4</td><td>250</td></tr> <tr><td>5</td><td>220</td></tr> <tr><td>6</td><td>180</td></tr> <tr><td>7</td><td>150</td></tr> <tr><td>8</td><td>125</td></tr> </tbody> </table> <p>Chart indicates that eight outputs can be ON simultaneously with each output collector current being 125mA. Outputs can hold 50 Volts in "Off" state.</p>	Number of Outputs "On"	Collector Current per Output (mA)	1	420	2	380	3	300	4	250	5	220	6	180	7	150	8	125
Number of Outputs "On"	Collector Current per Output (mA)																		
1	420																		
2	380																		
3	300																		
4	250																		
5	220																		
6	180																		
7	150																		
8	125																		
Connections	Supply & Antenna: 3-way screw type terminal block. 8 Outputs: 9-way screw type terminal block. (8 open collectors plus Ground)																		
Antenna	50 ohms, 27MHz CB-Antenna or approximately 1m long & 1mm thick piece of wire																		
Dimensions	96 X 70 X 15 mm																		
Mounting hole size	3.97 mm or 5/32"																		
Mounting Hole Spacing	Length 85 mm (3.34") Width 60 mm (2.36")																		
Weight	68g																		
Microcontroller	Can be re-programmed to suit your customised needs																		
Useable Transmitters	All Elsema Type 27MHz GLT-... series																		
Useable operating range	Up to 350m with proper 50 ohms, 27MHz CB-Antenna. Up to 200m with 1m long antenna wire. Antenna wire should be extended and away from metal. Ranges assume line-of-sight operation.																		

Block Diagram

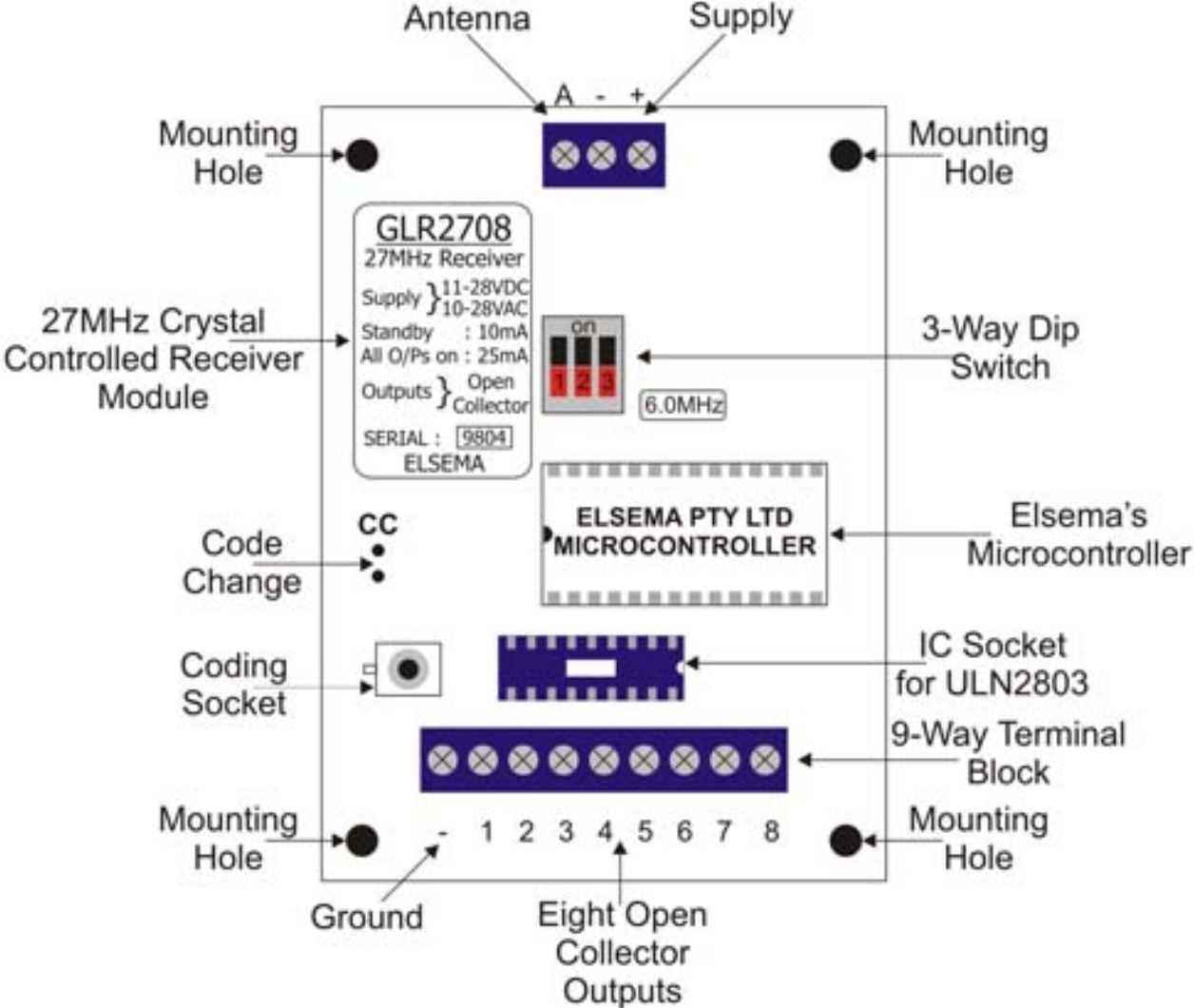

Application Notes (GLR2708)

Care should be taken with the solid-state outputs that they are protected from inductive loads. This is done by connecting diodes across your DC inductive load.

Inductive loads such as DC relays must be clamped with a diode across the relay coil. If this is not done the spikes generated by the DC relay will lock-up the receiver. When a lock-up occurs you will need to remove the power and re-connected it.

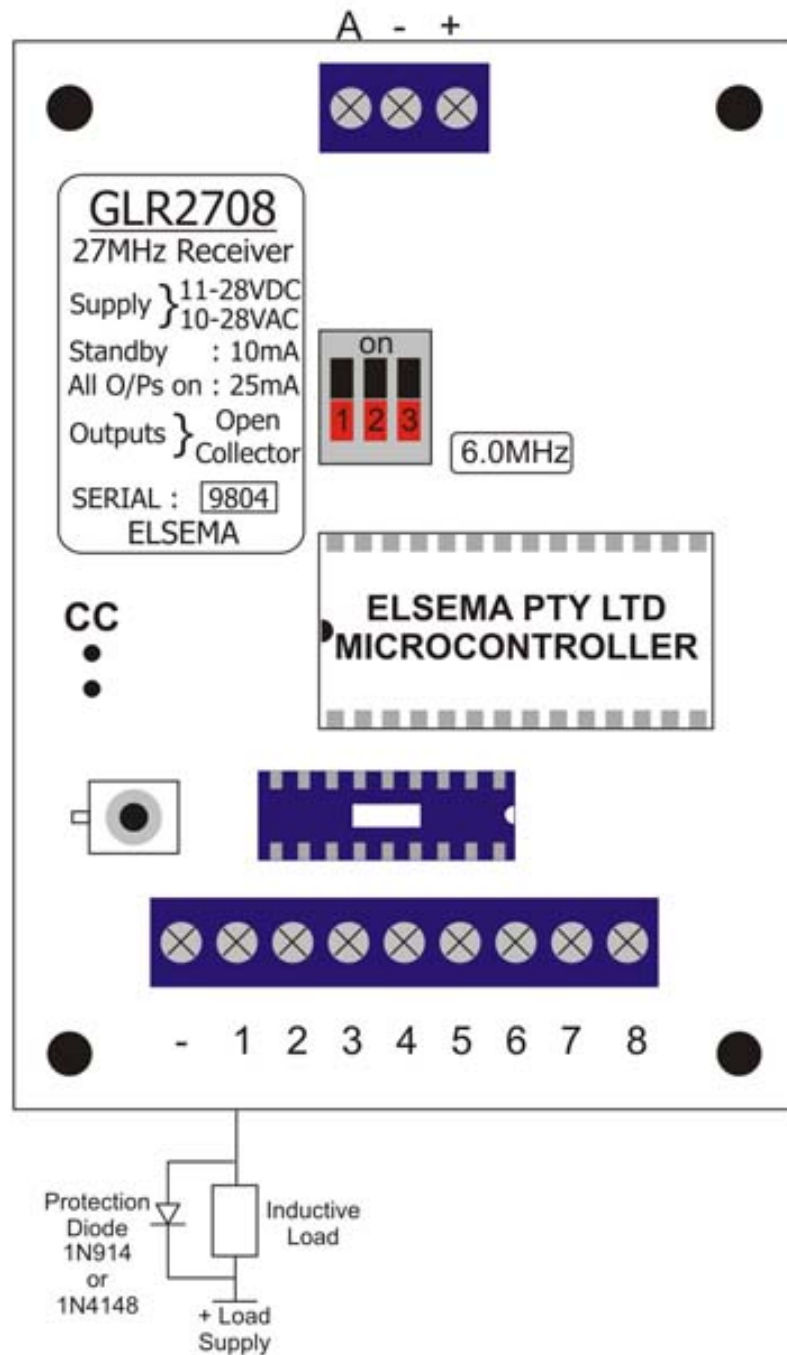

Manufactured by
Elsema Pty Ltd
3/10 Hume Rd, Smithfield
NSW 2164
Ph: 02 9609 4668
Fax: 02 9725 2663
Website: <http://www.elsema.com>